

# PRECISION BORE GAUGES (WITHOUT DIAL INDICATOR)

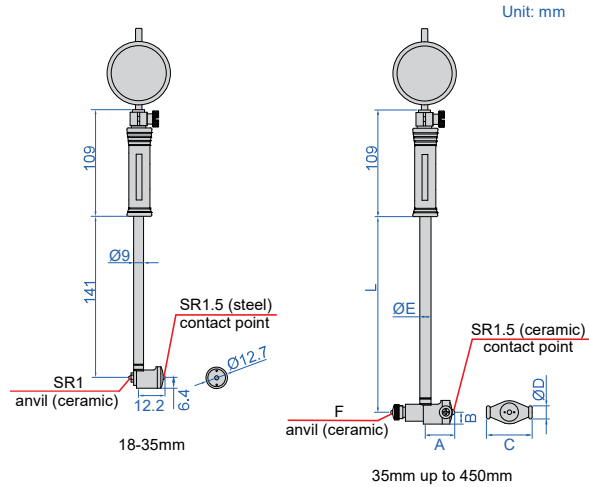

- Optional accessory: dial indicator, setting ring (code **6312**), bore gauge setter

Range	A	B	C	ØD	ØE	F	L
35-60mm	22	9	27	13	12.8	SR2	141
50-100mm	26	9	35	13	12.8	SR2	141
50-160mm	26	9	35	13	12.8	SR2	141
100-160mm	26	9	35	13	12.8	SR2	141
160-250mm	56.5	13	74.5	15	12.8	SR2	241
250-450mm	86.5	15	101.5	15	14.5	SR2.5	241

Code	Range	Accuracy (without dial indicator)	Repeatability (without dial indicator)
<b>2283-35</b>	18-35mm	±0.004mm	0.0015mm
<b>2283-60</b>	35-60mm	±0.004mm	0.0015mm
<b>2283-100</b>	50-100mm	±0.004mm	0.0015mm
<b>2283-160</b>	50-160mm	±0.004mm	0.0015mm
<b>2283-161</b>	100-160mm	±0.004mm	0.0015mm
<b>2283-250</b>	160-250mm	±0.004mm	0.0015mm
<b>2283-450</b>	250-450mm	±0.004mm	0.0015mm

dial indicator is optional



**2283-35**

dial indicator is optional



**2283-160**

